

Single Rotor Shredder for Tyres

Van Aarsen designs, produces and supplies shredders and other equipment for the tyre recycling industry, based on more than 20 years experience.

The shredders will downsize whole radial and steel belted car and truck tyres into shreds with irregular dimension depending on the mounted screen. Truck tyres need to be sliced prior to shredding.

Features of the Single Rotor Shredder

- Low operating costs
- Low maintenance costs
- Optimum operational utilization
- Minimum service down time
- Solid low maintenance construction
- Energy efficient motor with V-belt drive to shredder rotor
- Use of frequency converter for slow start-up and increase of flexibility
- Built completely according to the latest regulations and standards for safety.



Design

- Hopper for in-line feed of tyres to shredder.
- Heavy single shaft rotor with interchangeable rotor knives
- Interchangeable stator knives
- Interchangeable screen
- Shreds, which do not pass through the screen, will automatically return for a subsequent downsizing operation.
- Discharge of shreds in-line with in-feed of tyres or below 90 degrees with in-feed of tyres.
- Discharge of shreds by means of chute
- Shredder on frame for heavy-duty operation
- Platform for easy maintenance
- Electric drive with V-belt transmission and fixed speed only for car tyres (SRS1300M).
- Hydraulic drive with variable speed of rotor (SRS 1300H & SRS 1700H).
- Shredder with electric drive standard without control panel and terminal box.
- Shredder with hydraulic drive standard with control panel and terminal box.
- No special foundation or anchors in floor necessary for shredder
- For indoor and outdoor use. (From 0° up to 35°Celsius)
- According to CE safety regulations.

Maintenance

All wearing parts including the rotor and stator knives can be repeatedly maintained by means of welding and grinding. The knives can be removed from the shredder from a position on the platform. Ease of maintenance and short downtimes are the result. You are self-supportive in maintaining the machine, with no need for regular purchase of expensive wearing parts. Operational costs are kept to a minimum.

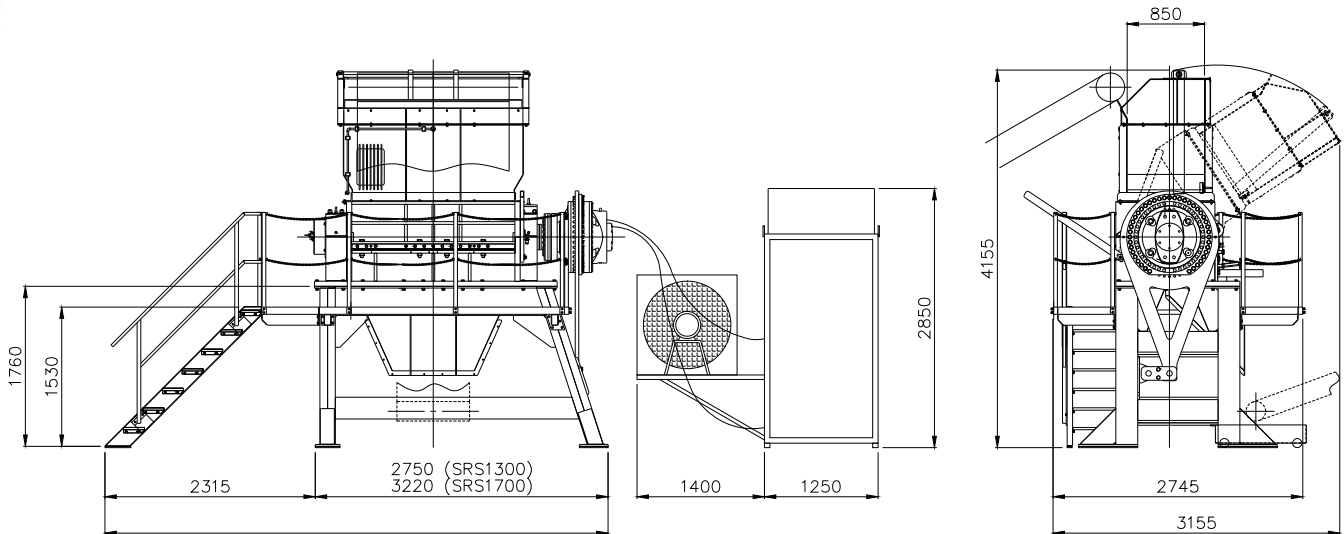

Shredder type	SRS1300M	SRS 1300H	SRS1700H
Input whole tyres (including bead)	Car	Car & Truck	Car & Truck & Agriculture
Maximum input size tyres	1300 x 450 mm	1300 x 450 mm	1700 x 450 mm
Maximum bead size tyres	Ø 13 mm	Ø 13 mm	Ø 13 mm
Number of rotor & stator knives	22 & 11	22 & 11	30 & 15
Screen interchangeable	Yes	Yes	Yes
Output size, irregular and average	100 x 150 mm.	100 x 150 mm.	100 x 150 mm
Exchange time of screen	45 minutes	45 minutes	45 minutes
Revolutions per minute of rotor	27	17 for truck and 27 for car tyres ²	17 for truck and 27 for car tyres ²
Throughput 100% truck tyres	Not possible	6 tons per hour maximum ¹	6 tons per hour maximum ¹
Throughput 100% car tyres	10 tons per hour maximum ¹	10 tons per hour maximum ¹	10 tons per hour maximum ¹
Drive power	132 kW	160 kW	160 kW
Maintenance cycle for knives	Approx. 1200 tons ¹	Approx. 1000 tons ¹	Approx. 1000 tons ²
Down time for maintenance knives	8 hours	8 hours	10 hours
Weight of shredder and frame	14.000 kg	14.000 kg	18.000 kg

¹ Based on shreds with an average size of 100 x 150 mm. Above mentioned tons are estimates and depend strongly on quality of tyres, knives, maintenance and revolutions of the rotor.

² The standard shredder is equipped with one speed of the rotor. If two speeds are required, then additional parts are required.